

## BRIGHT SPOTS SELECTION IN TV-IMAGES

*Valentina Tzekova, Emil Tzekov*

*Space Research Institute-Bulgarian Academy of Sciences*

### **Abstract**

*The aim of the present work is to propose a technique for separation of bright spots in TV-image background at low object signal to background signal ratio. It is shown that selection can be effected based on the front duration, using a differentiating circuit.*

In television control systems it is necessary to separate some objects from the surrounding background. Sometimes, they represent bright points in the television image. Quite often, these objects are separated by the method of amplitude selection. The method is accomplished rather easily, but it needs a high object-signal to background-signal ratio.

In the paper, an approach is suggested for selection of bright point objects in television images with small object-signal to background-signal ratio, even when this ratio is less than 1. The object selection is based on three parameters and can be accomplished quite easily.

According to [1], the television image is described by function  $I = f(x, y)$ , which expresses the image brightness in a point with coordinates  $(x, y)$ . In television systems, brightness is represented by the amplitude of the videosignal  $u_1(t)$ .

If in the television transmitter, progressive monolayer scanning is used, the videosignal of one series of the monolayer scanning may contain pulses from different bright objects and look as shown in Fig.1, where:

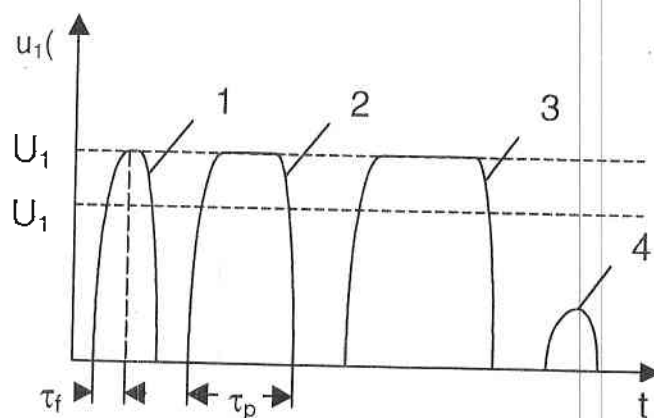

Fig. 1

1 - bright point object; 2 - object with fuzzy fronts; 3 - large-size object; 4 - point object of small brightness.

Let us assume that the pulse is obtained from a bright point object given its duration  $\tau_p$ , front duration  $\tau_f$  and amplitude  $U_p$  satisfy the following conditions:

$$(1) \quad \begin{aligned} \tau_{pmin} < \tau_p < \tau_{pmax}, \\ \tau_{fmin} < \tau_f < \tau_{fmax}, \\ U_p &\geq U_{pmin}. \end{aligned}$$

According to conditions (1), bright point objects may be selected by applying the flow chart shown in Fig.2, where: 1 - front duration selector; 2 - amplitude selector; 3 - pulse duration selector.

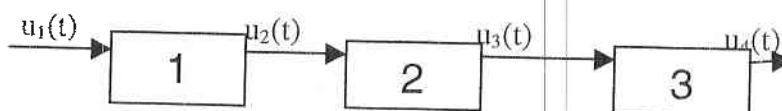

Fig. 2

The assumed sequence of parameter sign inspection was determined by the following reasons. In the process of selection by some specific parameter, the input signal is converted and part of the information contained

in it will be lost. Since front duration selection is the most difficult, it is reasonable that signal processing starts with it. In contrast to it, pulse duration selection does not require information about the signal's amplitude, therefore it can be done in the end of signal processing.

Front duration signal selection can be most easily accomplished by a simple differential RC circuit. Let us define the conditions for this selection with predetermined time constant of the RC circuit and videopulse front shape. With practically sufficient accuracy it may be assumed that the videopulse fronts have exponential form:

$$(2) \quad u_1(t) = U_1(1 - e^{-t/\tau_f}) \text{ when } t \geq 0.$$

The output signal of RC cell will be:

$$(3) \quad u_2(t) = U_1(e^{-t/\tau_f} - e^{-\beta t/\tau_f}) / (\beta - 1),$$

where:  $\beta = \tau_f / RC \neq 1$ .

With  $\beta = 1$ , the output signal is determined by the formula:

$$(4) \quad u_2(t) = U_1 e^{-t/\tau_f} t / \tau_f \text{ when } t \geq 0.$$

Function  $u_2(t)$  has maximum at:

$$(5) \quad t = \tau_f \ln \beta / (\beta - 1), \beta \neq 1 \text{ and}$$

$$(6) \quad t = \tau_f, \text{ when } \beta = 1.$$

From (3), (4), (5) and (6), we shall obtain the amplitude of output signal:

$$(7) \quad U_2 = U_1(e^{-\ln \beta / (\beta - 1)} - e^{-\beta \ln \beta / (\beta - 1)}) / (\beta - 1), \beta \neq 1 \text{ and}$$

$$(8) \quad U_2 = U_1 / e \approx 0,37U_1, \beta = 1.$$

The dependence of ratio  $U_2/U_1$  on  $\beta$  is shown in Fig.3.

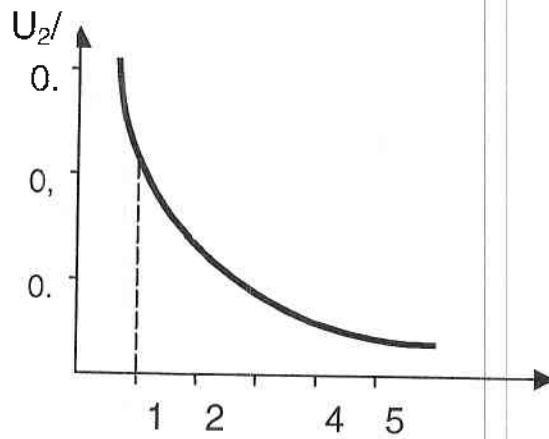

Fig. 3

Let us denote the background signals maximum amplitude by  $U_{1f}$ . For these signals,  $\beta_f > \beta_{\max} = \tau_{f\max} / RC \neq 1$ .

Then, when the background signal is fed up, the output signal of the differential circuit will have the amplitude:

$$(9) \quad U_{2f} < U_{1f} ( e^{-\ln\beta_{\max}/(\beta_{\max}-1)} - e^{-\beta_{\max}\ln\beta_{\max}/(\beta_{\max}-1)} ) / ( \beta_{\max} - 1 ) = k_f U_{1f} .$$

From inequality (9) it is seen, that the front duration selection task is reduced to the easy-to-perform amplitude selection of signals at the output of the differential circuit after the rule:

$$(10) \quad \tau_f \leq \tau_{f\max} , \text{ при } U_2 \leq k_f U_{1f} .$$

Let us assume that  $RC = \tau_{f\min}$ , i.e.  $\beta_{\min} = 1$  and let us find the minimum amplitude  $U_{1\min}$  of a pulse with front  $\tau_{f\min}$ , providing for satisfaction of condition (10). According to (8) and (10), we obtain:

$$U_{2\min} = U_{1\min} / c = k_f U_{1f}, \text{ or} \\ U_{1\min} = k_f e U_{1f} .$$

From these equations it is possible to find the minimum object-signal to background-signal ratio for selection of bright point objects:

$$(11) \quad U_{1 \min} / U_{1f} = k_f e.$$

It may be shown that, by increasing  $\beta_{\min}$ , the minimal object-signal to background-signal ratio slowly decreases, but simultaneously with it, the output signal amplitude decreases, too. To obtain a large enough amplitude  $U_2$ , it is reasonable to assume  $RC = \tau_{f \min}$ . Then, the minimal signal/background ratio will be:

$$\begin{aligned} U_{1 \min} / U_{1f} &= 0,68 && \text{with } \beta_{\max} = 2 \\ &\text{and} \\ U_{1 \min} / U_{1f} &= 0,53 && \text{with } \beta_{\max} = 3. \end{aligned}$$

It should be noted that the signals from back and front fronts of the videopulse have different polarity, which should be accounted for in applying rule (10).

In the cases where the minimum amplitude  $U_0$  of the bright point object videopulse should be greater than  $U_{1 \min}$ , rule (10) will change:

$$(12) \quad \tau_f \leq \tau_{f \max} \quad \text{and} \quad U_0 > U_1 \quad \text{at} \quad U_2 \geq U_0 / e.$$

Thus, rule (12) provides for a simultaneous selection by front duration and by amplitude.

Videopulse duration selection is no particular challenge; it may be accomplished by any of the methods described in literature.

With satisfaction of condition (1), except for the bright point objects, bright vertical or slanting lines in a TV image may be also selected. The selection of such objects is a rather difficult task, necessitating additional pulse analysis throughout several adjacent series of the monolayer scanning.

#### **Conclusions:**

1. Conditions for selection of bright point objects by videopulse within one series of monolayer scanning are formulated.
2. It is shown that the front duration selection task may be accomplished using a differential circuit.
3. Rules for selection of bright point objects are proposed.
4. It is shown that bright point objects can be selected with a signal/background less than 1.

## References

1. Розенфельд А. Т. Разпознаване и обработка изображения,

"Мир", 1972.

## СЕЛЕКТИРАНЕ НА ЯРКИ ТОЧКОВИ ОБЕКТИ В ТЕЛЕВИЗИОННО ИЗОБРАЖЕНИЕ

*Валентина Цекова, Емил Цеков*

### Резюме

Целта на настоящата работа е да се предложи начин за отделяне на ярки точкови обекти от околния фон в телевизионното изображение при малки отношения на сигнала от обекта към сигнала от фона. Показано е, че селекцията по продължителност на фронтите може да се извърши чрез използването на диференцираща верига.